

The WOODWAY Pro XL is designed for athletes seeking to maximize training effectiveness and performance

Training Performance

- High speeds (0-15 mph)
- Extreme elevation options (-3%) - (+22%) or 0-25%
- Multiple LED readouts monitoring speed, incline, distance, time, and heart rate
- Easy access trainer controls of speed, incline and stop

Patented Slat-Belt® Transportation System

- Individual slats with vulcanized rubber surface
- Zero stretch and Zero slip toothed, wire-reinforced lateral belts
- Near frictionless precision ball bearing rail guide

Safety and Reliability

- Emergency stop magnet and safety lanyard
- Polar monitor circuitry – integrated heart rate monitoring
- Advanced SlatFlex® shock absorption



Dimensions

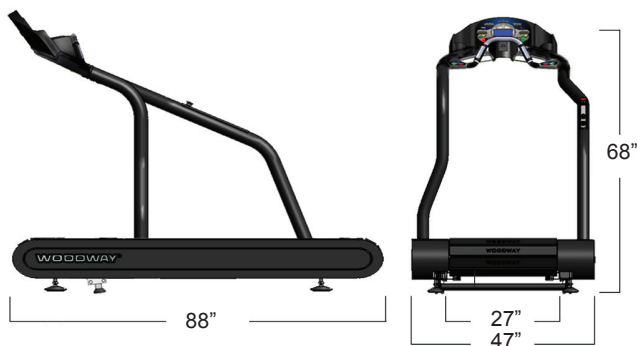

Increase functionality with the following Options:

- Personal Trainer Display
- Medical Package (hospital grade circuitry, reverse and 4 year parts warranty)
- Polar monitor chest strap
- Jump Plate
- RS-232 serial port interface (includes MedPro software)
- 0 – 16.5 mph speed range
- Silver handrails
- Reverse (0 – 5 mph)
- LCD TV (15" does not require separate power source)
- Personal DVD player (attaches to LCD TV unit)

Physical Specifications

Belt Type	87 individual slats
Drive System	160 precision ball bearings with 18 roller guides (4 mm lateral tolerance)
Running Surface	Vulcanized rubber (38-43 shore hardness)
Drive Motor	2 hp continuous (5 hp peak) brushless servo
Unit Weight	675 lb. (shipping weight 939 lb.)
Power Supply	220 V power supply (dedicated circuit and NEMA 6-20R outlet receptacle required)

Performance Specifications

User Weight Capacity	Running 500 lb. Walking 800 lb. (4 mph max)
Running Surface Area	27" X 88"
Speed Range	0 - 15 mph zero start 0.1 mph resolution
Elevation Range	(-3) - (+22%) or 0 - 25%
Standard Fitness Warranty	7 year wear warranty 5 year drive and motor 3 year all components 1 year labor



Personal Trainer Display

- Menu driven color LCD screen (shown above)
- 10 pre programmed workouts
- Ability to create custom user workouts (up to 99)
- Fitness testing (Pre loaded U.S. Military, Medical and Fire Department protocol)
- Animated Readouts (speed, incline, distance, calories, time/pace heart rate and METs)